



READ THE INSTRUCTION MANUAL BEFORE USING

INSTRUCTION MANUAL

MANOSTAR DIGITAL SENSOR

EMD8A066

No. TR-EMD8A066-E03

 **Yamamoto Electric Works Co., Ltd.**

1-2-3,Nishishiriike-cho,Nagata-ku,Kobe,653-0031 JAPAN

TEL. +81-78-631-6000 FAX. +81-78-631-6020

Manostar



TABLE OF CONTENTS

	PAGE
INTRODUCTION	1
I . PRECAUTIONS	2
II . SPECIFICATIONS	
1. Outline drawing	3
2. Function	
2-1 Display function	4
2-2 Digital communication function (MODBUS).....	5
2-3 Max. and min. value memory function	5
2-4 Function of low power consumption	5
2-5 Function of test mode	5
2-6 Function to clear set value	5
2-7 Function of set value protecting.....	6
III . INSTALLATION	
1. Installation conditions	6
2. Installation of instrument	6
3. Wiring.....	6
4. Piping	
4-1 Measured pressure and connection of piping	8
4-2 Piping material.....	9
4-3 Caution of piping.....	9
IV . OPERATION	
1. Before trial running	10
2. Operation panel	10
3. How to operate	
3-1 Change-over procedure of mode.....	10
3-2 Basic operation in each mode.....	13
3-3 Operation of test mode.....	14
3-4 Calibration for zero adjustment.....	14
4. MODBUS communication	
4-1 Communication specifications	15
4-2 Communication setting.....	15
4-3 Structure of message frame.....	15
4-4 Message examples	15
4-5 MODBUS address map.....	18
4-6 Status history list.....	19
4-7 List of communication error history	19
V . INFORMATION ON SOFTWARE	20
VI. PRODUCT WARRANTY	21

INTRODUCTION

Thank you very much for purchasing of “MANOSTAR DIGITAL SENSOR EMD8A”.

Features

• **Compact size**

This instrument is a compact digital micro differential pressure gage composed of the diaphragm type detection part and display part incorporated in 24 × 48 size.

• **Digital communication input/output (MODBUS)**

Thanks to the compatibility with RS-485 (MODBUS/RTU), it is possible to acquire measurement values as digital values and change settings from a remote location.

• **Employing an easy-to-see large seven segments LED**

Red-colored seven segment LED, 12 mm high character of high visibility, is used for 3•1/2 digits.

• **Simple operability**

This machine, designed for dedicated to pressure measurement, has simple operation set menu.

• **Low power consumption**

The electric power consumption is reduced by lowering the display luminance of LED.

• **Setting value protecting function**

It prevents a setting value to mistake by incorrect operation.

• **Test mode function**

Even when pressure is not actually applied, by setting a simulated pressure, it is possible to check the operation at the time of installation and inspection.

• **Max. and min. value memory function**

Max and min value of the measurement pressure are retained and it displays it.

• **Conformed to EU directive**

This instrument has been tested according to EMC standard EN IEC 61326-1:2021, and test levels have been applied to qualify for operation in an industrial environment.

• **UL recognized component**

 Caution	<p>To ensure your safety in using this instrument:</p> <ul style="list-style-type: none">• Be sure to read the instruction manual carefully before using this instrument so that you can use it properly.• Wrong use may result in failure of this instrument and lead to its damage and accident.• This manual should be kept in a proper place so that you can refer to it any time you need.
---	---

I . PRECAUTIONS

Warning

- **Do not use the instrument where flammable gas is present.**
The instrument is not explosion-proof. Do not use instruments in the circumstance where flammable gas is present. It may cause explosion.
- **Do not use the instrument at the place where corrosive gas is present.**
The instrument is not corrosion resistance construction. Measuring corrosive gas may corrode the receiving element and housing material of the instrument. It is expected that corrosive gas leaked out of the instrument will harm a person.
- **Do not apply the pressure to the instrument more than it can withstand.**
The diaphragm and the retainer are broken and cause of injury or accident, etc. disaster if the pressure exceeding withstanding pressure of the pressure receiving element is applied to the instrument. The case body and the transparent cover of the instrument are broken and cause of injury or accident, etc. disaster if the pressure exceeding withstanding pressure of the instrument body is applied to the instrument.
- **The instrument is measurable for air and non-corrosive gas only.**
The machine is exclusive use of dry air (85%RH or less). Using measuring the water or oil it may be damaged and causes the accident.
- **Avoid using where instrument is exposed to many vibration and impact.**
Using this instrument where intensified vibration and impact may be damaged instrument. It is expected that gas leaks of instrument which harms a person.
- **Do not exceed rated voltage in using.**
Using this instrument by exceeding rated voltage may cause fire or electric shock.
- **Wire correctly.**
Incorrect wiring may cause fire.
- **Do not exceed rated surrounding temperature, humidity and altitude in use.**
Using this instrument by exceeding rated surrounding temperature and humidity and altitude it may be damaged and cause the accident.
- **Do not disassemble or reconstruct your instrument.**
It may void your warranty.

Caution

- **Operate the keys on the operation panel with the fingers.**
Pressing a key with a hard or sharpened object may damage or break the surface of the key, possibly leading to a failure.
- **As to where to install and how to install the instrument, be sure to follow the instruction manual so as to ensure a proper method.**
- **Use the instrument indoors.**
- **In case of not being installed in dry and well-kept clean locations, the instrument must be enclosed in box.**
- **Electromagnetic emissions exceeding the requirements of the test standard can occur when the instrument is connected to a test object.**
- **Keep away from the devices which generate strong electromagnetic field. Furthermore, the wiring must be shielded from electromagnetic fields.**
If the instrument installed in strong electromagnetic field, it may cause the drift of accuracy display to be max.4%FS.
- **As the DC power supply to be connected to this sensor, use NEC (National Electrical Code) Class 2 power supplies or LPS (Limited Power Source) power supplies.**
- **Do not use organic solvent for cleaning.**
Use of organic solvent, such as thinner and benzene, to remove surface dirt and stain may cause melting and cracking on the surface. To remove dirt and stain, be sure to wipe them off with a wet cloth using diluted neutral cleanser.
- **Dropping the product.**
Product is a precision instrument. If you drop the product, there is a possibility that the exterior, also the interior mechanism damage.
- **Removal of the piping**
If you replace the old pipes, please do not pull the pipe with a strong force. There is a possibility that the pipe cap is broken.

II . SPECIFICATIONS

1. Outline drawing

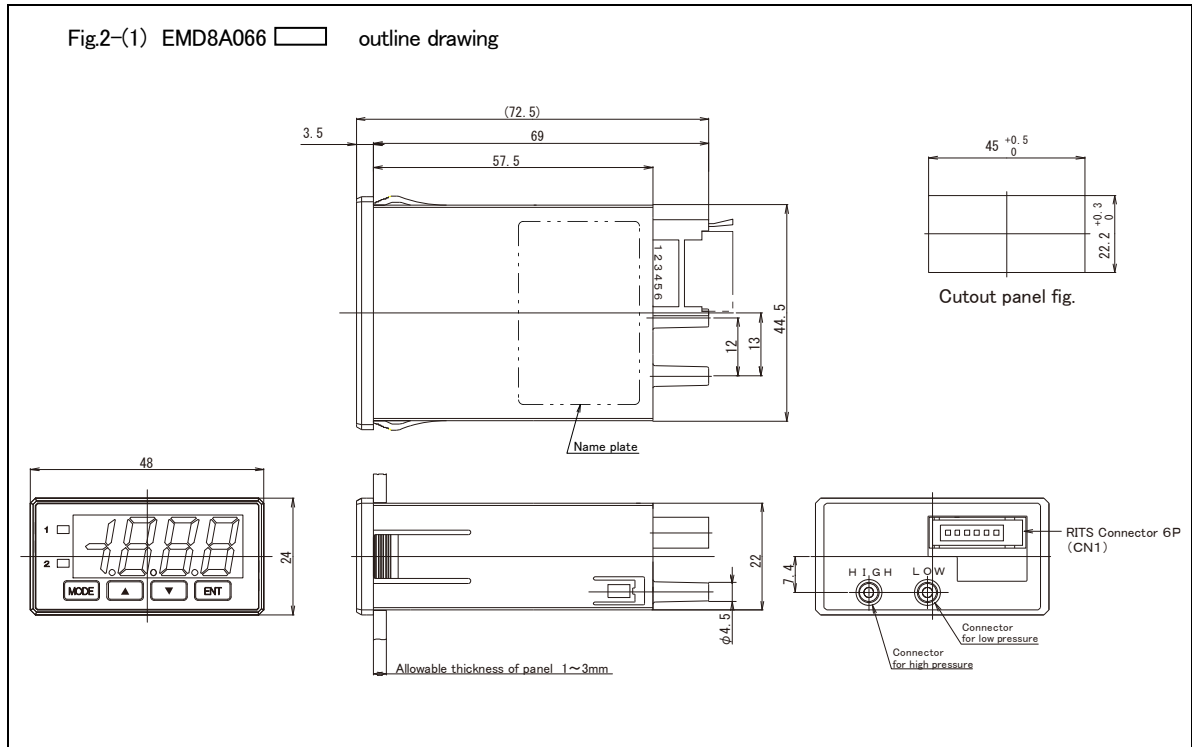

2. Function

The pressure sensor of this product can measure differential pressures. If the pressure on the H side is higher than that of the L side, the pressure display shows a positive value.

This sensor performs A/D conversion of the signal from the pressure sensor, then performs zero compensation and movement average processing, and finally displays the value and performs the digital communication output.

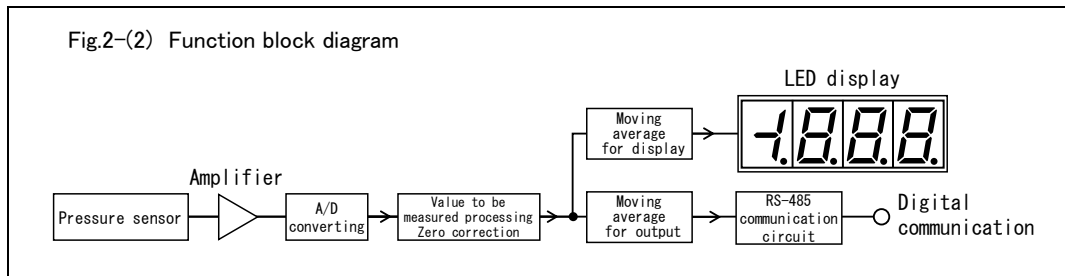

2-1 Display function

1) Display filter

The number of the moving average filter for display is set in the display filter setting mode. When the change of the measurement pressure is large, the change of the display value can be reduced by enlarging the average number of the moving average function. The response is late according to large a set value of the filter mode. It is possible to independently set the movement average filter for display use and that for digital communication output use.

When the instrument is shipped from our factory, is set to standard "1.0 sec."

Display filter mode		Average processing (Response time)
Setting value	F0.2	High speed (0.2 sec.)
	F1.0	Standard speed (1.0 sec.)
	F2.0	Low speed 1 (2.0 sec.)
	F4.0	Low speed 2 (4.0 sec.)

2) Overrange warning

The display pressure "FFF" and informs of the over range when pressure which exceeds the ratings pressure joins in this instrument. The display pressure "-FFF" when the difference pressure is negative.

•Over range pressure

- Mono (single) pressure range : 110% or more and -10% or less of the ratings pressure.
- Zero center (+-) pressure range : 60% or more and -60% or less of the ratings pressure.

3) Function of display low cut

It is a mode that compulsorily sets the indicated value to 0 when the measurement pressure indicated value is about 0. When setting value is "CT2" (2%FS), the value of less than $\pm 2\%FS$ becomes 0 displays. Please set CT0 (0%FS) when you do not use the function.

The low cut function applies only to the displayed value and does not affect the digital communication output.

4) Function of sign reversal of display measured

The sign of the display of the pressure display mode and the max and the min value display mode is inverted. This function is used to invert the sign when negative pressure is measured. Please refer to P.8 "4-1 Measured pressure and connection of piping" for the usage of this function.

2-2 Digital communication function (MODBUS)

1) Digital communication (input/output)

By means of RS-485 (MODBUS/RTU) communication, it is possible to acquire pressure measurement values, execute zero adjustment, and change the various settings.

For the items and effective value ranges, refer to P.18 “4-5 MODBUS address map”.

2) Output filter

The number of the moving average filter for digital communication output is set in the output filter setting mode. When the change of the measurement pressure is large, the change of the output value can be reduced by enlarging the average number of the moving average function. The response is late according to large a set value of the filter mode. It is possible to independently set the movement average filter for display use and that for digital communication output use.

When the instrument is shipped from our factory, is set to standard “1.0 sec.”.

Output filter mode		Average processing (Response time)
Setting value	F0.2	High speed (0.2 sec.)
	F1.0	Standard speed (1.0 sec.)
	F2.0	Low speed 1 (2.0 sec.)
	F4.0	Low speed 2 (4.0 sec.)

3) Function of sign reversal of digital communication output

This function inverts the signs of pressure measurement value, maximum value, and minimum value, and then outputs them. This function is used to invert the sign when negative pressure is measured. Please refer to P.8 “4-1 Measured pressure and connection of piping” for the usage of this function.

2-3 Max. and min. value memory function

Each value is displayed and the max. value and the min. value of the pressure measurement value can be reset in the max. value memory display mode or the min. value display mode. the max. value and the min. value memory is reset once the power supply to this sensor is turned off.

2-4 Function of low power consumption

The electric power consumption is reduced by lowering the display luminance of LED. It is not influenced about other functions at all. The display luminance only at the pressure display mode falls and other program modes etc. become usual luminance’s when the function is on.

2-5 Function of test mode

This function tests whether the parameter setting is correctly set when the device is set up and checked. In this mode, simulative pressure can operate the device without applying actual pressure. This function is used to check the operation by changing the simulative pressure. The simulative-pressure-value is automatically set to present-pressure-value at the time of shifting to test-mode. A simulative setting pressure is not preserved. The display blinks for the test mode recognition when shifting to the test mode. It is recognized that the blinking display is not a pressure display mode. The pressure display mode by the passage of 15 seconds in the no operation time doesn’t return in this mode automatically.

2-6 Function to clear set value

In the setting clear mode, it is possible to revert the setting values in each mode to the factory default setting values.

For the factory default setting values, refer to P.12 “Mode table”.



Caution

Performing setting clear deletes the current setting values.

2-7 Function of set value protecting

It becomes impossible to change set value by each program mode when set value protecting is set. It prevents a set mistake by the miss operation etc. etc. Please release protecting only when the setting change is necessary.

III. INSTALLATION

1. Installation conditions

The following places should be avoided for installation of this unit.

- Don't install where there are intense vibration and impact are applied to this unit.
- Don't install where there is sudden fluctuation of surrounding temperature or place where this unit is exposed to direct sunlight.
- Don't install where high humidity exists, where water or oil splashes over the unit or where there is much dust.
- Don't install where corrosive gas or flammable gas is generated.

2. Installation of instrument

Insert EMD8A body into the panel hole and press the flange of EMD8A enough against the panel so that it hits the panel surface.

Use a metal material such as steel or a material with equivalent strength for the panel.

 Caution	•installation position : Vertical only.
--	---

3. Wiring

External connection diagram is shown in Fig.3- (1). The connection example when an external equipment is connected is shown in Fig.3- (2).

When using MODBUS communication, it is possible to connect multiple pieces of this sensor to a single master. (According to RS-485 standard, it is possible to connect 31 pieces of this sensor at maximum.)

While the maximum communication distance is 500 m, it varies depending on the installation conditions (number of connected products and noise environment).

Connect a terminating resistor at the end of the line as necessary.

 Caution	•Do not let rating of each terminal go beyond the specifications. •When wiring, be sure to separate the wiring from the wiring of power supply.
--	--

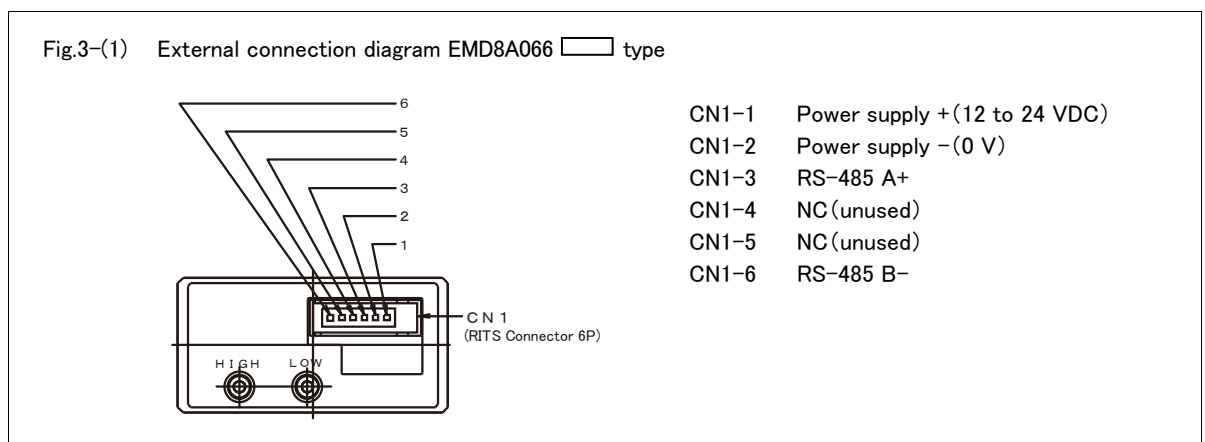
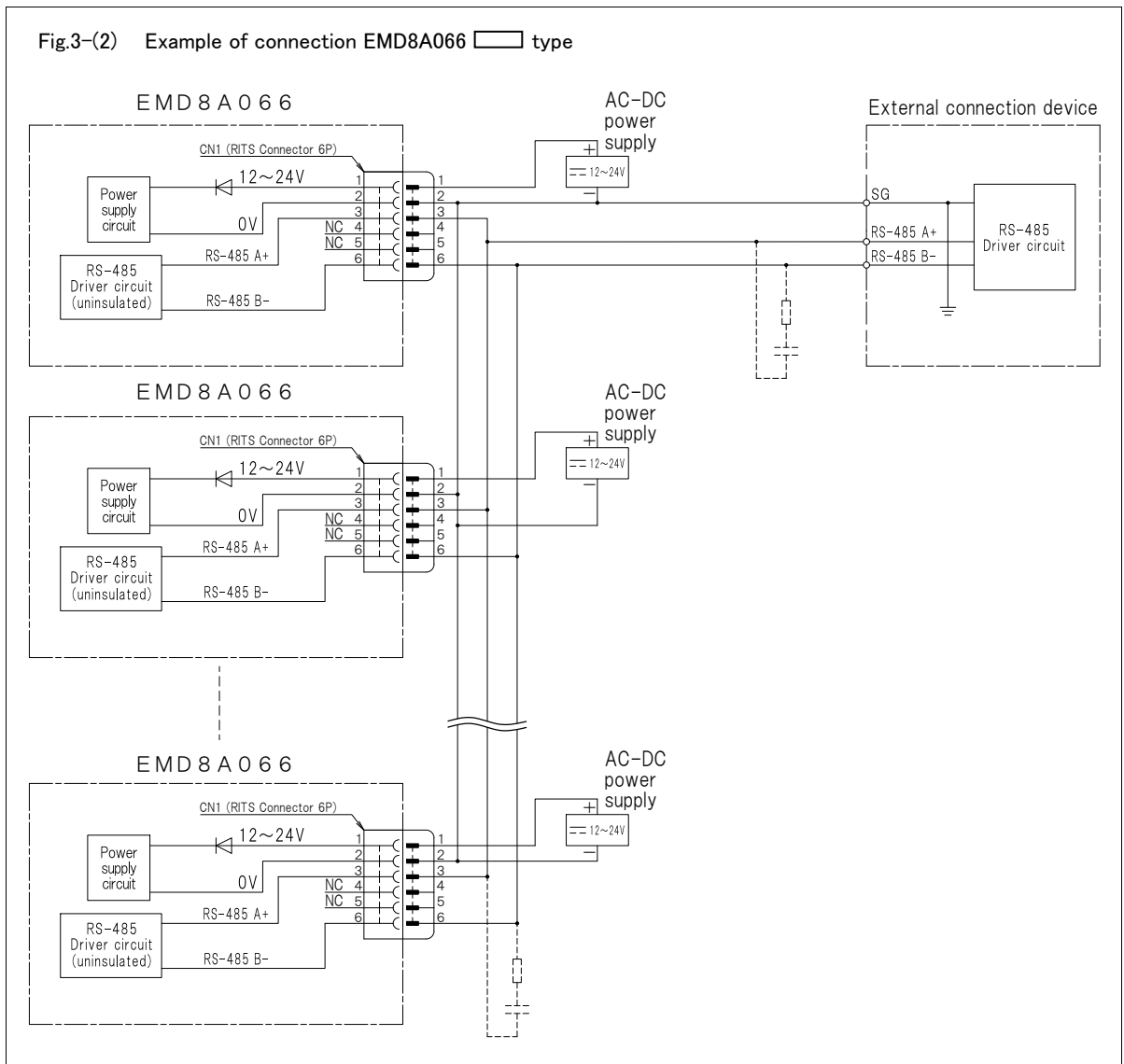



Fig.3-(2) Example of connection EMD8A066 type



Accessory

•RITS plug connector 6P (produced by TE Connectivity)

Product code	Color of cover	Applied cable		
		Nominal cross-sectional areas	O.D of the wire cover	
1473562-6	Yellow	0.1~0.5mm ²	1.0~1.15mm	

 Caution	<ul style="list-style-type: none"> • For crimping wire to connector, a RITS plug connector must be used. • RITS plug connector is not compatible to other manufacturer's connector because it is not compliant with the industry standard "e-CON". (The standard "e-CON" is only used in Japan.) • For crimping wire to connector, a specific RITS plug connector (TE Connectivity), product number 1729940, must be used. • For further inquiry on the detail of RITS plug connector and the other tools, please contact TE Connectivity directly.
---	---

4. Piping

The instrument, a differential pressure gage, is provided with taps at the rear side : one for high pressure (HIGH) and the other for low pressure (LOW).

Depending on the application and use, connect piping as follows.

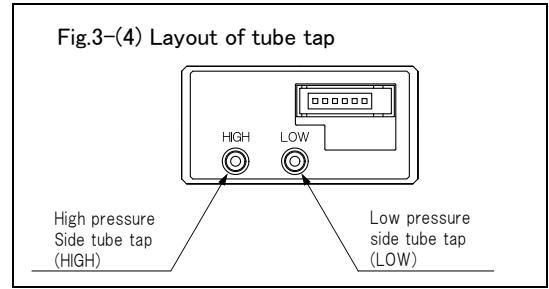

4-1 Measured pressure and connection of piping

Please connect the piping shown in the table below according to the measured pressure, and set the function of inverting sign of measurement display.

Measurement pressure		Differential pressure	Gage pressure	
Usage		Differential pressure measurement	Positive pressure measurement	Negative pressure measurement
Piping	High pressure side tube tap HIGH	Measurement pressure (high)	Measurement pressure (positive pressure)	Open to atmosphere
	Low pressure side tube tap LOW	Measurement pressure (low)	Open to atmosphere	Measurement pressure (negative pressure)
Function sign reversal of display measured		oFF	oFF	on
Function of sign reversal of digital communication output		oFF	oFF	on

 Caution	<p>For gage pressure measurement with the instrument of zero-center range (+ -), connect piping to high pressure tap in order to match symbol on the display (+, -) and the actual polarity inside the tubing pressure.</p> <p>For zero-center range (+-), unless there is a special reason, set P.4 "Function of sign reversal of display measured" and P.5 "Function of sign reversal of digital communication output" to OFF.</p>
--------------------	--

 Caution	<p>When one side of tap is open to atmospheric air, be sure to provide air vent at the outside of panel, or the port released and open in the panel (box of device etc.), has been exposed to in-panel pressure generated by air flow to cool down inside of panel forcibly by fan, etc.</p>
--------------------	--

Fig.3-(5)

4-2 Piping material

For tubing material used for taps of this unit, be sure to use tubing material of I.D 4.

Vinyl or rubber tubes are suitable.

As shown in Fig.3-(6), when inserting the piping into the tap, be sure to push it in until the piping hit the bottom of tap.

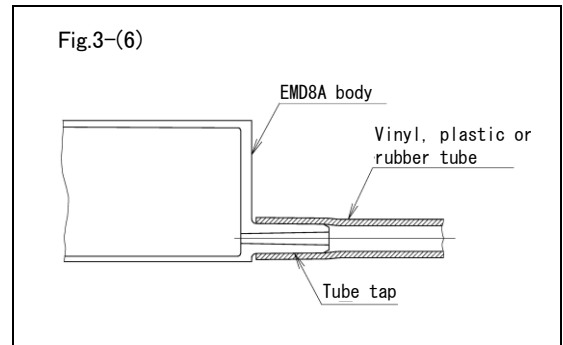

 Caution	<p>When connecting or disconnecting the piping to the tube tap, please be sure to grasp the sides of case (the shaded area in Fig.3-(7)) firmly with your fingers.</p> <p>Do not apply strong force to either the top or bottom surfaces of the case.</p>
---	---

Fig.3-(7)



4-3 Caution of piping

Prohibition of common piping

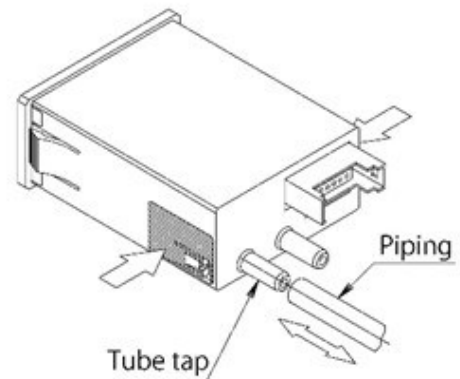
Piping each of pressure detectors and pressure receiving instruments tube exclusively dedicated for it, and do not connect the piping commonly with the adjacent system as shown in Fig.3-(8).

Errors caused by long distance piping

The speed of response is delayed when the product is used for remote monitoring. In such application, the I.D. of the connection tube should be as large as possible.

If the piping conditions of the high and low pressure side are significantly different, the difference in the piping resistance between high and low pressure side causes the difference in pressure transmission time, and the measurement becomes inaccurate.

Prevention of clogging at tubes caused by drain

- If drain remains within the line, it causes measurement error. Be sure to install the pressure receiving instrument above the pressure outlet port of the pressure detector and arrange the line so that the drain water should not remain in the slack piping.
- If the arrangement mentioned above in not possible, install a drain tank and clean it once in a while.
- After the cleaning of the tank, check that the air tightness is fully kept.

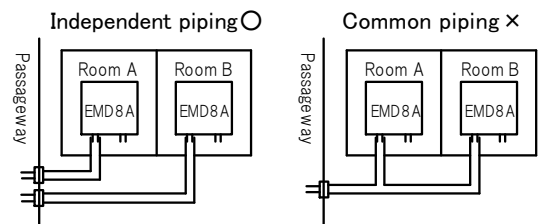

Fig.3-(8)

IV. OPERATION

1. Before trial running

Before supplying power to this unit for the first time after installation, take care of the following matters.

1) Make sure again of the followings and see if they are correct: location of installation, environment and how the instrument is installed, wiring and piping etc.

Supplying power with wrong wiring and piping may lead to instrument failure and accidents.

2) Before supplying power, take measures on other devices and the machine in which this sensor is incorporated so that they will not be affected.

2. Operation panel

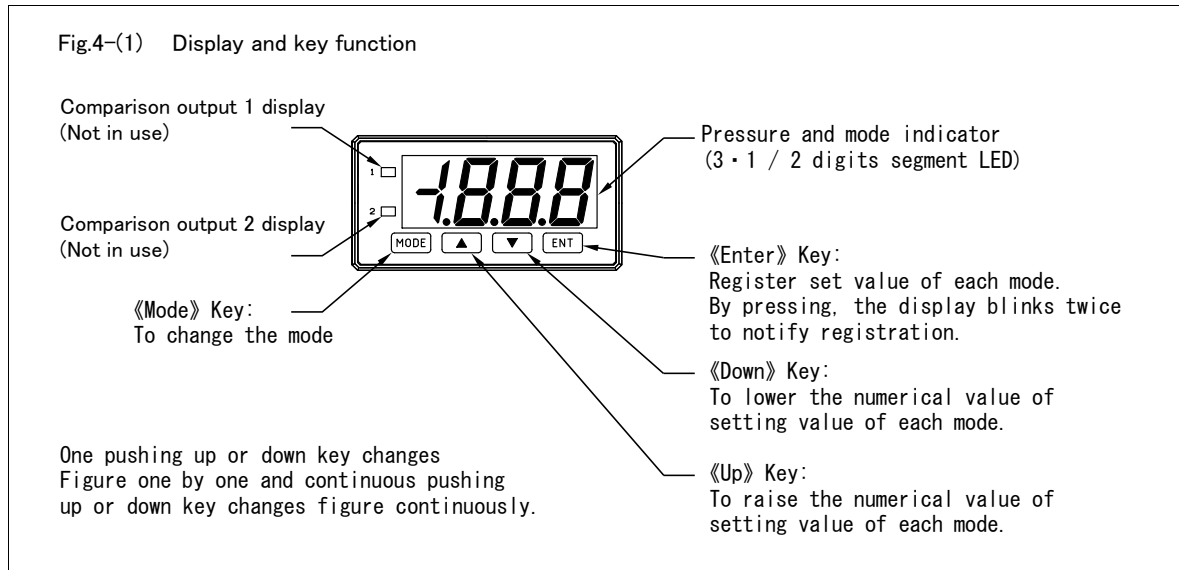

3. How to operate

3-1 Change-over procedure of mode

Please switch to each mode one by one by «Mode» key operation as shown in the Fig.4-(2). Holding down «Mode» key for two seconds or longer enters the setting mode.

It automatically returns to the pressure display mode when there is no key input even if 15 seconds or more pass from the last key input. However, it excludes «Up»«Down» key input waiting state of setting mode.

Even if the power supply is intercepted, a set value of each mode is maintained excluding the max. and the min. value memory, and the test mode.

Please refer to P.12 “Mode table” for the factory default setting.

Fig.4-(2) Change-over of mode (Please refer to P.10 "3. How to operate" for a basic operation in each mode.)

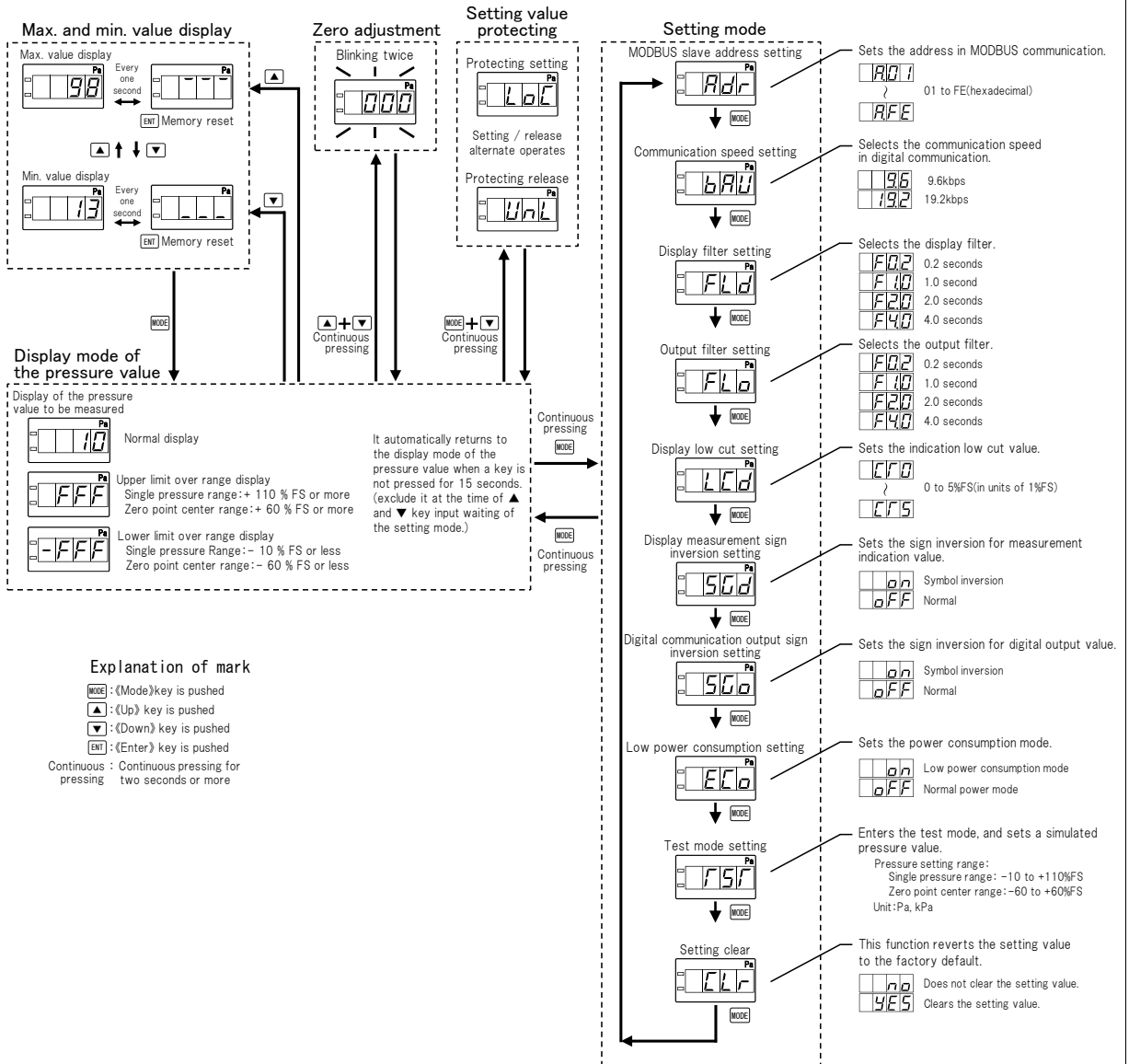

Mode table

Mode type	Mode name	Mode display	Factory default setting			Setting range	
			Display	Set value	Unit		
Pressure display	Normal	□□□□	—	—	Pa / kPa	—	
	Upper limit over range	□FFF	—	—	—	—	
	Lower limit over range	□-FFF	—	—	—	—	
Quick	Zero adjustment	□000	—	No zero corrections	—	—	
	Setting value protecting	—	□UnL	Protecting release	—	UnL / LoC	
	Max. value display	□□□□	—	—	Pa / kPa	—	
	Min. value display	□□□□	—	—	Pa / kPa	—	
Setting	MODBUS slave address	□Adr	□□□□	01	—	01~FE (hexadecimal)	
	Communication speed	□bAU	□□□□	9.6kbps	bps	9.6k / 19.2k	
	Filter	Display	□FLd	□□□□	Response time 1.0 seconds	seconds	0.2sec/1sec/2sec/4sec
		Output	□FLo	□□□□	Response time 1.0 seconds	seconds	
	Display low cut	□LCD	□□□□	±2%FS	±%FS	±%FS	0~5%FS (every 1%FS)
	Sign reversal of display measured	□SGn	□□□□	Off	—	—	on / oFF
	Sign reversal of Digital communication output	□SGo	□□□□	Off	—	—	on / oFF
	Low power consumption	□ECO	□□□□	Off	—	—	on / oFF
	Test mode	□FSF	—	—	—	—	Mono: -10~+110%FS ± : -60~+60%FS
Setting clear mode	□CLR	□□□□	(factory default setting)	—	—	—	

*All setting values are set to the factory default setting in the setting clear mode.

3-2 Basic operation in each mode

Please refer to P.11 “Fig.4-(2) Change-over of mode” for the order of shifting each mode etc. As for the following items, it is executable from the pressure display mode according to a quick operation. All basic operations of other each program mode are united as shown in Fig.4- (3).

Quick operation

$\boxed{\blacktriangle} + \boxed{\blacktriangledown} + \text{LP}$	Zero adjustment
$\boxed{\text{MODE}} + \boxed{\blacktriangledown} + \text{LP}$	Setting value protecting
$\boxed{\blacktriangle}$	Max. value display
$\boxed{\blacktriangledown}$	Min. value display

LP: Continuous pressing for two seconds or more

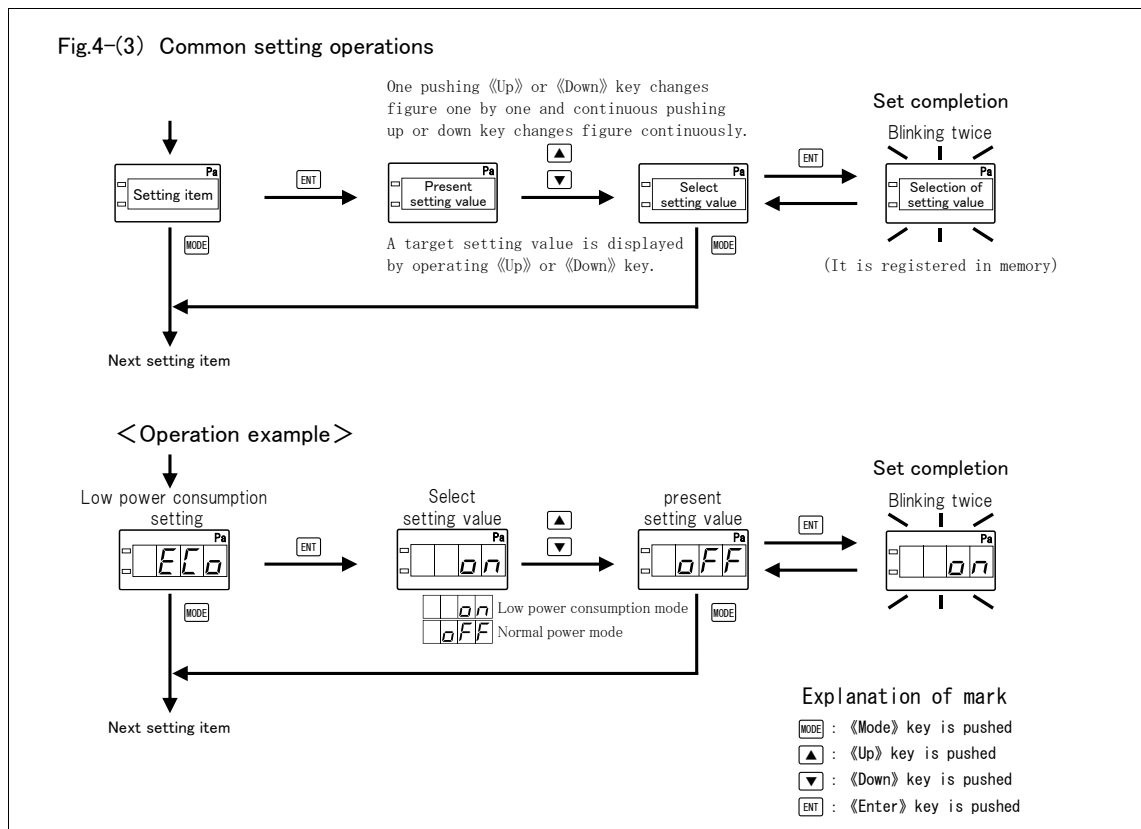

1) Registration of set value

It moves from the pressure display mode to each mode one by one by «Mode» key operation. When «Enter» key is pushed with becoming the display of a target mode, present value is displayed, and state moves in the state of value input. Next, after the display value is adjusted to a target set value by operating «Up» «Down» key, «Enter» key is pushed. Then, the display blinks twice and registration to the memory is completed. It is not registered until «Enter» key is pushed even if setting display value is changed.

2) Operation of set value

When a set value is changed in each mode, a set value grows if «Up» key is pushed, and if «Down» key is pushed, a set value becomes small. It becomes a lower bound if «Up» key is pushed when the indicated value is an upper limit, and if «Down» key is pushed at the lower bound, it becomes an upper limit. The value increases and decreases continuously when press and hold a key (key repeat operation). The range which can be set is different depending on each mode.

3) Error and command protecting when setting is operated

The display becomes $\boxed{\text{L}}\boxed{\text{O}}\boxed{\text{F}}$ and registration becomes invalid at the time of the command protecting. The setting and release alternately change into the setting value protecting at each quick operation.

($\boxed{\text{MODE}} + \boxed{\blacktriangledown} + \text{LP}$)

4) Clearing of the Max. and Min. value

It becomes the following with $\langle\langle$ Enter $\rangle\rangle$ key in the following mode.

- Max. value display mode : The max.value is reset.
- Min. value display mode : The min.value is reset.

5) Set value clear mode : A set each value is returned to the state of the factory shipment.

When "YES" is selected in set value clear mode and $\langle\langle$ Enter $\rangle\rangle$ key is pressed, all set values are restored in the state of factory shipment. When "no" is selected, clearness is not executed. Default is "no" so as not to clear by mistake.

3-3 Operation of test mode

The measurement pressure value immediately before is set as simulative pressure value immediately after the shift of the test mode. And, the state becomes a test mode at once. Even if $\langle\langle$ Enter $\rangle\rangle$ key is not pressed, the increase and decrease of value with $\langle\langle$ Up $\rangle\rangle$ $\langle\langle$ Down $\rangle\rangle$ key becomes effective at once.

3-4 Calibration for zero adjustment

To set the current pressure indication value to 0% FS, adjust the offset between the indicated value and the digital communication output value.

As the zero adjustment processes internal data whose accuracy is higher than the indicated pressure, this function works even when the pressure indication is "0."

[Operation procedure]

- 1) Leaving pressure tubes open to atmospheric air on the H side as well as L side, let this unit have no pressure applied.
- 2) In accordance with P.10 "3-1 Change-over procedure of mode", return to the pressure display mode.
- 3) Press $\langle\langle$ Up $\rangle\rangle$ key and $\langle\langle$ Down $\rangle\rangle$ key at the same time for two seconds or more. The display informs of zero adjustment completion by the display's becoming "000" and blinking twice.
- 4) Reconnect tubes back to normal and this puts an end to operation.

Note)

When the pressure display value shifts by $\pm 20\%$ or more to the factory shipment, zero adjustment can not to be done. At this time, the display shows $\boxed{E} \boxed{r} \boxed{r}$.

 Caution	<ul style="list-style-type: none">• Before conducting zero adjustment, perform a warm-up operation for 15 minutes or longer after turning on of the power supply.• Be sure to conduct zero adjustment with the product in a correct installation orientation by surely avoiding application of pressure to both the H and L side bases (open to atmosphere) or stopping the machine operation and reducing the residual pressure to zero.• After zero adjustment has completed, be sure to put the pipes back.
--	--

4. MODBUS communication

4-1 Communication specifications

Communication method	EIA-485 (RS-485)
Protocol	MODBUS/RTU
Communication speed	9.6kbps ,19.2kbps
Data length	8 bits (fixed)
Parity	None (fixed)
Stop bit	1 bit (fixed)
Address setting range	1 to 254 (01 to FE)

4-2 Communication setting

Set the slave address and communication speed in accordance with P.11 “Fig.4-(2) Change-over of mode”.

*The factory default settings are “slave address: 01” and “communication speed: 9.6 kbps.”

4-3 Structure of message frame

The message frame of MODBUS/RTU is as follows.

Start	Slave address	Function code	Data	CRC	End
Non-communication time (For 3.5 characters)	1 byte	1 byte	n bytes	2 bytes	Non-communication time (For 3.5 characters)

When “0” is set to the slave address, broadcast communication is enabled, and writing is performed in all pieces of this sensor on the same bus.

*Function codes 05 and 16 only.

4-4 Message examples

Function code 03: Acquire “Pressure range code” in slave address 01.

Query

01 03 00 04 00 01 C5 CB

Start	Slave address	Function code	Data				CRC		End
			Start address	Number of registers					
-	01	03	00	04	00	01	C5	CB	-

 Caution	<ul style="list-style-type: none"> •Items cannot be continuously read. •Except in acquisition of “Manufacturing number” and “Slave address,” set “00 01” to “Number of registers.” (In acquisition of “Manufacturing number” and “Slave address,” set “00 02” to “Number of registers.”)
---	---

Response *when pressure range code is “06”

01 03 02 00 06 38 46

Start	Slave address	Function code	Data			CRC		End
			Number of bytes	Description				
-	01	03	02	00	06	38	46	-

Function code 04: Acquire “Pressure value” in slave address 01.

Query

01 04 00 00 00 01 31 CA

Start	Slave address	Function code	Data				CRC		End
			Start address		Number of registers				
-	01	04	00	00	00	01	31	CA	-

 Caution	Items cannot be continuously read. Set “00 01” to “Number of registers.”
--	--

Response *when pressure value is “100”

01 04 02 00 64 B8 DB

Start	Slave address	Function code	Data			CRC		End
			Number of bytes	Acquired data				
-	01	04	02	00	64	B8	DB	-

Function code 05: Execute “Zero adjustment” in slave address 01.

Query

01 05 00 00 00 01 0C 0A

Start	Slave address	Function code	Data				CRC		End
			Start address		Changed data				
-	01	05	00	00	00	01	0C	0A	-

*When “0” is set to the slave address, broadcast communication is enabled.

Response

01 05 00 00 00 01 0C 0A

Start	Slave address	Function code	Data				CRC		End
			Start address		Changed data				
-	01	05	00	00	00	01	0C	0A	-

*In broadcast communication, there is no response.

Function code 16 (0x10): Enable “Low power consumption mode” in slave address 01.

Query

01 10 00 00 00 01 02 00 01 67 90

Start	Slave address	Function code	Data							CRC		End
			Start address		Number of registers		Number of bytes	Changed data				
-	01	10	00	00	00	01	02	00	01	67	90	-

*When “0” is set to the slave address, broadcast communication is enabled.

 Caution	<ul style="list-style-type: none"> •Items cannot be continuously written. •Except in setting of “Slave address,” set “00 01” to “Number of registers” and “02” to “Number of bytes.” (In setting of “Slave address,” set “00 02” to “Number of registers” and “04” to “Number of bytes.”)
--	--

Response

01 10 00 00 00 01 01 C9

Start	Slave address	Function code	Data				CRC		End
			Start address		Number of registers				
-	01	10	00	00	00	01	01	C9	-

*In broadcast communication, there is no response.

4-5 MODBUS address map

The details of addresses are as shown in the table below.

MODBUS address map

Read / Write	Function code	Address	Data type	Data size	Item	Effective data range	Reference	Initial value
R	04	0	Signed integer	2 bytes	Pressure value	Same as pressure range indication (Example: -10.0 to 110.0 Pa → -100 to 1100) * The decimal point in the indicated value is omitted.	-	-
R	04	1	Signed integer	2 bytes	Pressure ratio	Mono : -1000 to 11000 (-10 to 110% FS) ± : -6000 to 6000 (-60 to 60% FS)	-	-
R	04	2	Signed integer	2 bytes	Maximum pressurization value	Same as item "Pressure value"	-	-
R	04	3	Signed integer	2 bytes	Minimum pressurization value	Same as item "Pressure value"	-	-
R	04	4	Unsigned integer	2 bytes	Communication error history	Refer to "4-7 List of communication error history."	P.19	00
R	04	5	Unsigned integer	2 bytes	Status history	Refer to "4-6 Status history list."	P.19	00
W	05	0	Boolean	1 bit	Zero adjustment	1: Execute zero adjustment.	P.14	0
W	05	1	Boolean	1 bit	Clearing of maximum value/minimum value	1: Clear maximum value/minimum value.	P.5	0
W	05	2	Boolean	1 bit	Clearing of maximum value	1: Clear maximum value.	P.5	0
W	05	3	Boolean	1 bit	Clearing of minimum value	1: Clear minimum value.	P.5	0
W	05	4	Boolean	1 bit	Clearing of error	1: Clear information on error that has occurred.	-	0
W	05	100	Boolean	1 bit	Restart	1: Restart the device.	-	0
W	05	200	Boolean	1 bit	Factory default setting	1: Reset the setting values in each mode to the factory default setting values. * Setting of slave address is also reset.	P.12	0
R/W	03 / 16	0	Unsigned integer	1 byte	Low power consumption mode	0: disable 1: enable	P.5	0
R/W	03 / 16	1	Unsigned integer	1 byte	Setting value protection	0: disable 1: enable	P.6	0
R	03	2	Unsigned integer	4 bytes	Manufacturing number	-	-	-
R	03	4	Unsigned integer	1 byte	Pressure range code	06: D50 08: D100 11: D200 12: D300 13: D500 16: D1000 21: D+50 22: D+100 23: D+200 24: D+300 25: D+500	-	-
R/W	03 / 16	5	Unsigned integer	1 byte	Display low cut	0 to 5 (0 to 5%)	P.4	02
R/W	03 / 16	7	Unsigned integer	1 byte	Function of sign reversal of display measured	0: disable 1: enable	P.4	0
R/W	03 / 16	8	Unsigned integer	1 byte	Display filter	0: 200 ms 1: 1000 ms 2: 2000 ms 3: 4000 ms	P.4	1
R/W	03 / 16	10	Unsigned integer	1 byte	Output filter	0: 200 ms 1: 1000 ms 2: 2000 ms 3: 4000 ms	P.5	1
R/W	03 / 16	11	Unsigned integer	1 byte	Function of sign reversal of digital communication output	0: disable 1: enable	P.5	0
R/W	03 / 16	13	Unsigned integer	4 bytes	Slave address	1 to 254 (01 to FE)	-	01
R/W	03 / 16	15	Unsigned integer	1 byte	Communication speed	03: 9.6 kbps 05: 19.2 kbps	-	03



Caution

- "Continuous reading" and "continuous writing" of items are impossible.
- Do not perform writing to other than writable address. Failure to follow this instruction may cause a failure.

4-6 Status history list

The presence/absence of status abnormality is indicated by the lower 6 bits.

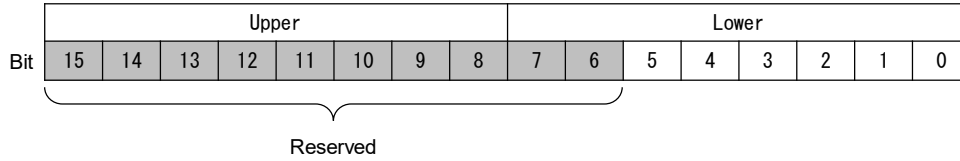

Bit	Item	Description
0	Overflow	0: normal 1: occurrence of overflow When an overflow has occurred, this bit turns to "1."
1	Underflow	0: normal 1: occurrence of underflow When an underflow has occurred, this bit turns to "1."
2	MODBUS error	0: normal 1: occurrence of communication error When an error related to MODBUS communication has occurred, this bit turns to "1."
3	EEPROM rewriting limit error	0: normal 1: EEPROM has reached the rewrite limit When the number of rewritings of internal EEPROM has reached the limit (100,000 times), this bit turns to "1."
4	EEPROM writing error	0: normal 1: occurrence of EEPROM writing error When writing is disabled due to breakage of EEPROM, noise, or the like, this bit turns to "1."
5	Zero adjustment error	0: normal 1: failure of zero adjustment When zero adjustment has failed, this bit turns to "1." *The pressure indication value at the time of implementation of zero adjustment may be deviated from the factory default setting by $\pm 20\%$ or greater. Check the zero adjustment procedures, and then implement zero adjustment again. 3-4 Calibration for zero adjustment" on page 14
6~15	Reserved	

*An error from which the device has already been restored will be cleared after reading is performed once.

4-7 List of communication error history

The presence/absence of communication error is indicated by the lower 3 bits.

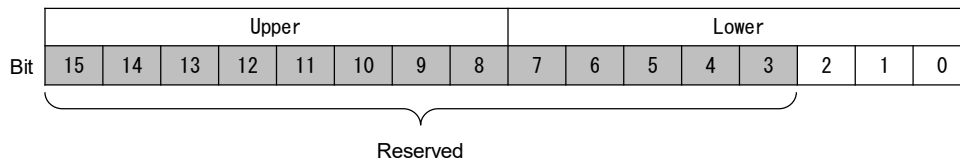

Bit	Item	Description
0	Invalid command	0: normal 1: reception of invalid function code When a request for unsupported function code is received, this bit turns to "1."
1	Invalid address	0: normal 1: reception of invalid address When a request for unsupported address is received, this bit turns to "1."
2	Invalid data	0: normal 1: reception of invalid data When a request for writing of value out of the effective range is received, this bit turns to "1."
3 to 15	Reserved	

*An error from which the device has already been restored will be cleared after reading is performed once.

V . INFORMATION ON SOFTWARE

In part of this sensor, the following OSS (open-source software) is used.

The product use FreeRTOS. More detail read below.

* FreeRTOS Kernel V10.0.1

* Copyright (C) 2017 Amazon.com, Inc. or its affiliates. All Rights Reserved.

*

* Permission is hereby granted, free of charge, to any person obtaining a copy of

* this software and associated documentation files (the "Software"), to deal in

* the Software without restriction, including without limitation the rights to

* use, copy, modify, merge, publish, distribute, sublicense, and/or sell copies of

* the Software, and to permit persons to whom the Software is furnished to do so,

* subject to the following conditions:

*

* The above copyright notice and this permission notice shall be included in all

* copies or substantial portions of the Software.

*

* THE SOFTWARE IS PROVIDED "AS IS", WITHOUT WARRANTY OF ANY KIND, EXPRESS OR

* IMPLIED, INCLUDING BUT NOT LIMITED TO THE WARRANTIES OF MERCHANTABILITY, FITNESS

* FOR A PARTICULAR PURPOSE AND NONINFRINGEMENT. IN NO EVENT SHALL THE AUTHORS OR

* COPYRIGHT HOLDERS BE LIABLE FOR ANY CLAIM, DAMAGES OR OTHER LIABILITY, WHETHER

* IN AN ACTION OF CONTRACT, TORT OR OTHERWISE, ARISING FROM, OUT OF OR IN

* CONNECTION WITH THE SOFTWARE OR THE USE OR OTHER DEALINGS IN THE SOFTWARE.

*

* <http://www.FreeRTOS.org>

* <http://aws.amazon.com/freertos>

VI. PRODUCT WARRANTY

Warranty Period

The warranty period shall be for one year from the date that the product has been delivered to the location specified by the purchaser.

Warranty Scope

In the event of any failure or defect in the product or non-conformity of specifications due to the reasons solely attributable to Yamamoto Electric Works, Yamamoto Electric Works shall remedy such malfunctioning or defective product at its own cost in one of the following ways to be selected by Yamamoto Electric Works:

- i) repair such product, ii) replace such product.

However, this Warranty shall not cover the damages or defects that arise due to any of the following reasons.

- (1) Any failure resulting from improper conditions, improper environments, improper handling, or improper usage other than described in the instruction manual or the specifications arranged between the purchaser and Yamamoto Electric Works.
- (2) Any failure resulting from factors other than a defect of our product, such as the purchaser's equipment or the design of the purchaser's software.
- (3) Any failure resulting from modifications or repairs carried out by any person other than Yamamoto Electric Works' staff.
- (4) Any failure caused by a factor that cannot be foreseen at a scientific/technical level at the time when the product has been shipped from Yamamoto Electric Works.
- (5) Any disaster such as fire, earthquake, and flood, or any other external factor, such as abnormal voltage, for which we are not liable.

Yamamoto Electric Works specifically disclaims all implied warranties of merchantability and/or fitness for a particular use or purpose, as well as liability for incidental, special, indirect, consequential or other damages relating to the product.

*This product warranty is only valid within Japan.

Product Applicability

Our products are designed and manufactured as general-purpose products for general industries. Therefore, our products are not intended for the applications below and are not applicable to them.

- (1) Facilities where the product may greatly affect human life or property, such as nuclear power plants, aviation, railroads, ships, motor vehicles, or medical equipment
- (2) Public utilities such as electricity, gas, or water services
- (3) Usage outdoors, under similar conditions or in similar environments

This document has been translated from the original Japanese version, and the original Japanese version takes first priority.

Be sure to refer to the original Japanese for the details of this warranty.

<Prior notice>

The specifications and description of the product explained in this instruction manual may be subject to change without prior notice because of modification and the like.