

Accessories

Pitot tube

RoHS

Static pressure tube For static pressure measurement in measurement of airflow rate/airflow speed (dynamic pressure) in pipes

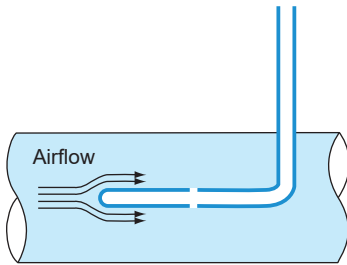

For vinyl pipe

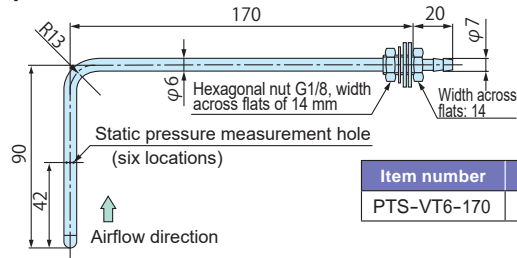

Item number	Material	Panel cutting
PTS-VT6-170	Brass/steel	φ10.5

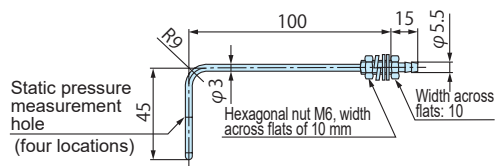

Item number	Material	Panel cutting
PTS-VT4-100	Brass/phosphor bronze	φ6.5

For metallic pipe

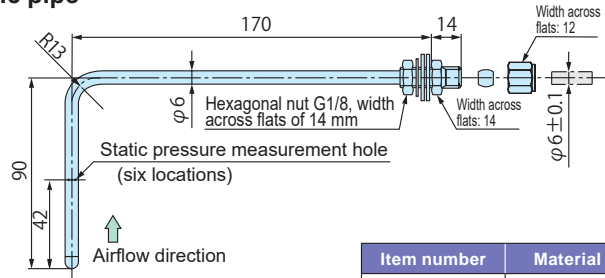

Item number	Material	Panel cutting
PTS-MT6-170	Brass/steel	φ10.5

PT base

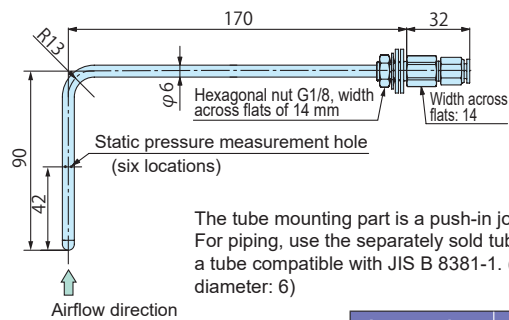

The tube mounting part is a push-in joint.
For piping, use the separately sold tube (refer to page 112) or a tube compatible with JIS B 8381-1. (Connectable tube outer diameter: 6)

Item number	Material	Panel cutting
PTS-PT6-170	PBT, brass, steel	φ10.5

PR base

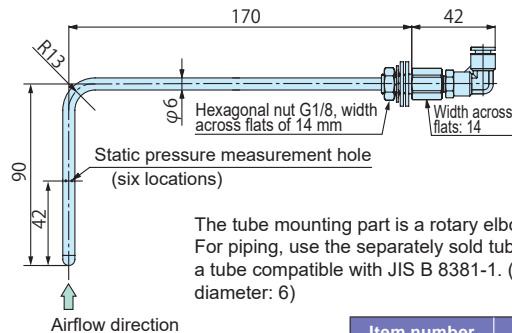

The tube mounting part is a rotary elbow push-in joint.
For piping, use the separately sold tube (refer to page 112) or a tube compatible with JIS B 8381-1. (Connectable tube outer diameter: 6)

Item number	Material	Panel cutting
PTS-PR6-170	PBT, brass, steel	φ10.5



List of products

WO81

WO71

FR51A

MS99

MS99S

MS61A-RA

QDP33

EMD8A

EMD7

EMT1

EMTGP1

EMT1H

EMT6

EMP5A

EMRT1

HWS15A

Accessories

Application

Precautions

Maintenance

Accessories

How to use the Pitot tube

List of products

WO81

WO71

FR51A

MS99

MS99S

MS61A-RA

QDP33

EMD8A

EMD7

EMT1

EMTGP1

EMT1H

EMT6

EMP5A

EMRT1

HWS15A

Accessories

Application

Precautions

Maintenance

Measurement method of static pressure and dynamic pressure

Measurement method of static pressure

1. Method using static pressure pipe
2. Method using a static pressure hole, which is a smooth hole made along duct inner wall so that no protrusion into the duct is made
3. Method using pipe (simplified Pitot tube) at an orthogonal angle to the duct inner wall. However, to use this method, the flow speed must be 1 m/s or below. If the flow speed is higher than that, the error will be greater because of the influence of the dynamic pressure.

Measurement method of dynamic pressure

To know a flow speed, only measuring the dynamic pressure of the flow obtains it. However, the dynamic pressure cannot be directly measured. Therefore, use the formula below.

$$\text{Total pressure} - \text{Static pressure} = \text{Dynamic pressure}$$

The dynamic pressure can be obtained from the differential pressure between the pressure at the total pressure pipe and that at the static pressure pipe.

1. Method of installing static pressure pipe and total pressure pipe at a distance D between them. (Refer to page 116)
2. Method of installing overall/static pressure pipe

Diagram for explanation of total pressure, static pressure, and dynamic pressure

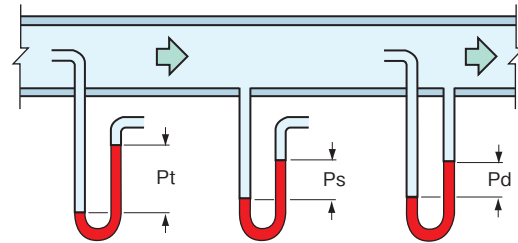

$$P_t \text{ (total pressure)} = P_s \text{ (static pressure)} + P_d \text{ (dynamic pressure)}$$

Measurement method of static pressure and dynamic pressure

The measurement method for flow speed using the Pitot tube is relatively simple and highly reliable, but as the airflow speed decreases, the detection pressures (total pressure, static pressure) and the differential pressure (dynamic pressure) between them also decrease, and accurate measurement is disabled at an airflow speed of 2 m/s or lower.

Calculation formula of flow speed by means of the Pitot tube

$$V \text{ (m/s)} = \sqrt{\frac{2}{\rho} (P_t - P_s)}$$

Where,

ρ : Fluid density (kg/m³)

P_t : Total pressure (Pa)

P_s : Static pressure (Pa)

Density of dry air at 0°C and one atmosphere $\rho = 1.293 \text{ kg/m}^3$

Airflow speed - dynamic pressure relationship table

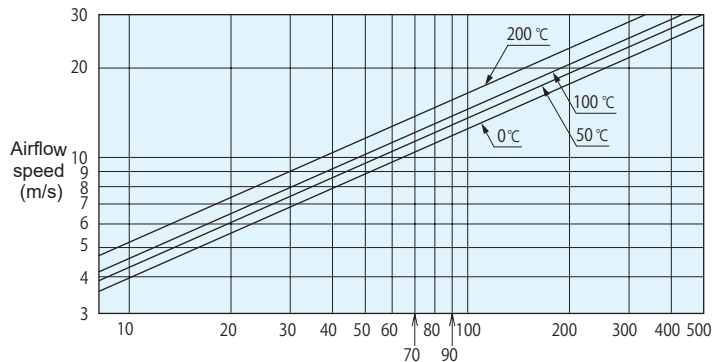

Total pressure - Static pressure = Dynamic pressure (Pa)

Measurement of airflow rate by means of the Pitot tube

- Set the tip straight pipe part of the Pitot tube in parallel to the flow. As the measurement points, set the 10 points on each of two diameter lines that cross each other at the right angle on the measurement pipe cross section, 20 points in total, as shown in the formula on the right. However, as this method requires substantial time and effort, it is not suitable for commercial use.
- Use of a composite Pitot tube, in which Pitot tubes in large number are used, is convenient.
- Method to obtain approximate flow rate by measuring the maximum airflow speed at the center of pipe with a single Pitot tube
Flow rate = Maximum airflow speed × Pipe cross section area × 0.9

Measurement points in Pitot tube

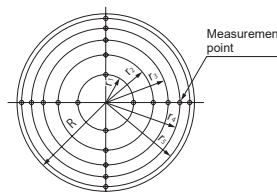

- $r_1 = 0.316R$
- $r_2 = 0.548R$
- $r_3 = 0.707R$
- $r_4 = 0.837R$
- $r_5 = 0.949R$

Composite Pitot tube



NEW AEROEYE

*NEW AEROEYE is a product manufactured and sold by Wetmaster Co., Ltd.

How to use the Pitot tube

Guide for Pitot tube installation location

Depending on the pipe layout, the flow may be disturbed, which may affect the measurement accuracy. Therefore, when installing a Pitot tube, we recommend securing a sufficient straight pipe length equal to or greater than the corresponding value in the table below.

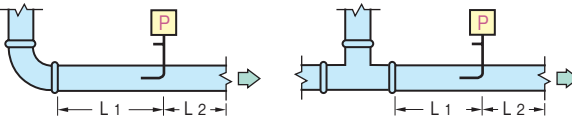
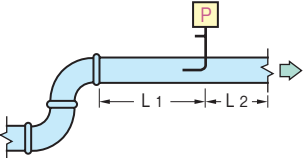
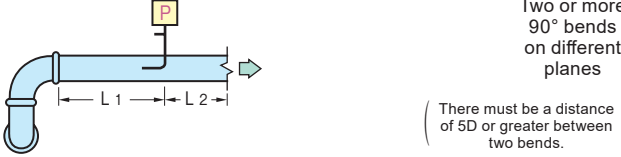
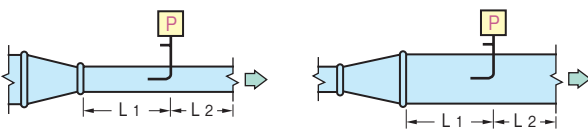
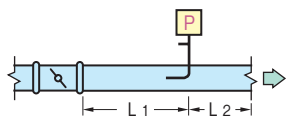
 Pitot tube installation location D: Duct diameter Round duct D = duct inner diameter Square duct D = (duct inner width + height) / 2	Dimension on upstream side (L1)	Dimension on downstream side (L2)
	Without flow straightener	
 <p>90° bend or single tee</p>	6D	4D
 <p>Two or more 90° bends on the same plane</p>	10D	4D
 <p>Two or more 90° bends on different planes (There must be a distance of 5D or greater between two bends.)</p>	19D	4D
 <p>Shrinking pipe or expanding pipe</p>	6D	4D
 <p>Gate valve, fully open</p>	12D	4D

List of products

WO81

WO71

FR51A

MS99

MS99S

MS61A-RA

QDP33

EMD8A

EMD7

EMT1

EMTGP1

EMT1H

EMT6

EMP5A

EMRT1

HWS15A

Accessories

Application

Precautions

Maintenance

Warranty

Warranty period

The warranty period for our product is one (1) year from delivery to the location specified by the orderer who makes a direct transaction with us.

Scope of warranty

If any failure or defect attributable to us becomes clear during the above warranty period, we will repair the product or supply a substitute product free of charge. However, even during the warranty period, we will exclude the product from the scope of the warranty if the failure or defect corresponds to any of the following:

- (1) The failure or defect was caused by an unreasonable condition, environment, handling, or usage not mentioned in the instruction manual, specifications, and our product catalog.
- (2) The failure or defect was caused by a factor other than our product.
- (3) The failure or defect was caused by a modification or repair conducted by a party other than us.
- (4) The failure or defect was caused by an event that could not be foreseen at the scientific and technical levels at the time of product shipment from us.
- (5) The failure or defect was caused by an external factor not attributable to us, such as acts of God and disasters.

Please note that the warranty mentioned here means the warranty for our individual product, and damage provoked by a failure or defect of the product is excluded from the scope of the warranty.

*This warranty is valid only in Japan.

Application and usage

Our products are designed and manufactured as general-purpose instruments for general industries.

Therefore, our products are not intended for the following uses, and our products used in such a manner are outside the scope of application.

- (1) Equipment that is anticipated to greatly affect lives and properties, such as nuclear power generation, aviation, railways, marine vessels, vehicles, and medical devices
- (2) Utilities that include electricity, gas, and service water
- (3) Use in outdoor locations and under similar conditions or environments other than those stipulated in the instruction manual
- (4) Usage to which considerable safety consideration and attention equivalent to (1) and (2) above need to be given

Service

Scope of service

Because the product price does not include service expenses, such as the dispatch of engineers, we will separately charge for the expenses in the following cases:

- (1) Instruction for installation and adjustment and a witnessed test run
- (2) Maintenance inspection, adjustments, and repairs
- (3) Technical guidance and technical education
- (4) Witnessed inspections of products at our factory

<<Note>> The product specifications and information in this catalog are subject to change without prior notice for product improvement or other reasons.

● For order placement, contact

General agent  **Manostar Shop Co., Ltd.**

1-2-3 Nishishiriike-cho, Nagata-ku, Kobe City, Hyogo 653-0031
TEL. +81-78-621-7000 FAX. +81-78-621-7788

Manufacturer  **Yamamoto Electric Works Co., Ltd.**

1-2-3 Nishishiriike-cho, Nagata-ku, Kobe City, Hyogo 653-0031
TEL. +81-78-631-6000 FAX. +81-78-631-6020